

FEATURES

- Customizable printed glass with 4 touch areas with backlight.
- 1.18" OLED display (128x128 pixels).
- 2 analog/digital inputs.
- Thermostat.
- Clock functionality (subject to updating through devices with RTC or NTP client).
- Touch confirmation through acoustic feedback.
- Proximity and luminosity sensor.
- Total data saving on KNX bus failure.
- Integrated KNX BCU.
- Dimensions 55 x 55 x 36mm.
- Flush mounted in mechanism box.
- Conformity with the CE directives (CE-mark on the back side).

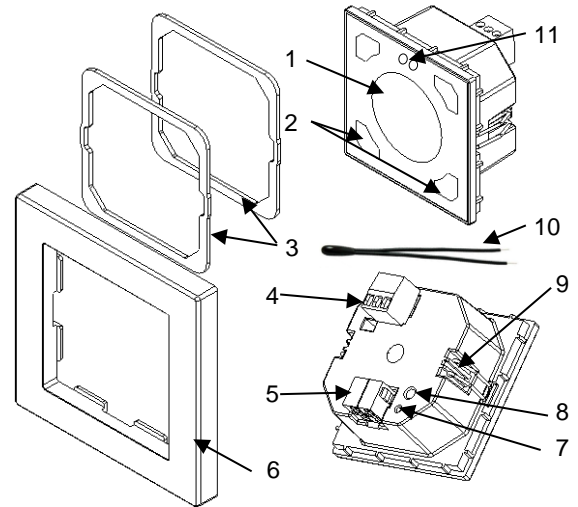

Figure 1: Flat 55 Display

1. Display	2. Touch areas	3. Metallic levelling plate (1 and 1.5mm)	4. Inputs connector
5. KNX connector	6. Frame (sold separately)	7. Programming LED	8. Programming button
9. Fixing clips	10. Temperature probe ref. 9900015 (included)	11. Luminosity and proximity sensor	

Programming button: short press to set programming mode. If this button is held while plugging the device into the KNX bus, it enters the safe mode.

Programming LED: programming mode indicator (red). When the device enters the safe mode, it blinks (red) every half second. During the start-up (reset or after KNX bus failure) and if the device is not in safe mode, it emits a red flash.

GENERAL SPECIFICATIONS

CONCEPT		DESCRIPTION		
Type of device		Electric operation control device		
KNX supply	Voltage (typical)	29VDC SELV		
	Voltage range	21..31VDC		
	Maximum consumption	Voltage	mA	mW
		29VDC (typical)	20.6	597.4
24VDC ¹	25	600		
Connection type		Typical TP1 bus connector for 0.80mm Ø rigid cable		
External power supply		Not required		
Operation temperature		0°C .. +55°C		
Storage temperature		-20°C .. +55°C		
Operation humidity		5 .. 95% (No condens.)		
Storage humidity		5 .. 95% (No condens.)		
Complementary characteristics		Class B		
Protection class		III		
Operation type		Continuous operation		
Device action type		Type 1		
Electrical stress period		Long		
Degree of protection		IP20, clean environment		
Installation		Flush mount on mechanism box.		
Minimum clearances		Not required		
Response on KNX bus failure		Data saving according to parameterization		
Response on KNX bus restart		Data recovery according to parameterization		
Operation indicator		The programming LED indicates programming mode (red). Backlighting of touch areas and display depends on their / the parameterization.		
Weight		68g		
PCB CTI index		175V		
Housing material		PC+ABS FR V0 halogen free		

¹ Maximum consumption in the worst case scenario (KNX Fan-In model)

INPUTS SPECIFICATIONS AND CONNECTIONS	
CONCEPT	DESCRIPTION
Number of inputs	2
Inputs per common	2
Operation voltage	+3.3VDC in the common
Operation current	1mA @ 3.3VDC (per input)
Switching type	Dry voltage contacts between input and common
Connection method	Pluggable screw terminal block
Cable cross-section	0.2-1.5mm ² (IEC) / 28-14AWG (UL)
Maximum cable length	30m
NTC probe length	1.5m (up to 30m)
NTC accuracy (@ 25°C) ²	±0.5°C
Temperature resolution	0.1°C
Maximum response time	10ms

² For Zennio temperature probes.

FRAME TEMPERATURE SENSOR SPECIFICATIONS	
CONCEPT	DESCRIPTION
Measuring range	-40 .. +105°C
Temperature resolution	0.1°C
NTC accuracy (@ 25°C)	±0.5°C

INPUTS CONNECTION

Any combination of the next **accessories** is allowed on the inputs:

Temperature Probe** ***

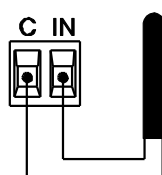

Zennio temperature probe.

Motion Sensor



Up to two motion sensors can be plugged into the same device input (parallel wiring)

Motion sensor screw terminal.

Motion sensor references:
ZN110-DETEC-X
ZN110-DETEC-P*

Switch/Sensor/ Push button

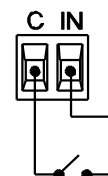

* The micro switch number 2 in the ZN110-DETEC-P must be in **Type B position** to work properly.

** May be a Zennio temperature probe or any NTC with known resistance values at three points in the range [-55, 150°C].

*** To use the included temperature probe, a proper thermal transfer must be ensured, for example, by installing it in a cable outlet or by drilling a small hole in case of using the frame of the device itself.

INSTALLATION INSTRUCTIONS

- Place the metallic piece into a squared or rounded standard mounting box with the own screws from the box.
* (Optional) Insert the metallic levelling plate/s so the frame stays at the desired level.
- Connect the KNX bus at the rear of the device, as well as the inputs terminal. Fix the frame to the device.
- Fit the device in the metal plate. The device is anchored thanks to the fixing clips.
To uninstall proceed the reverse way.

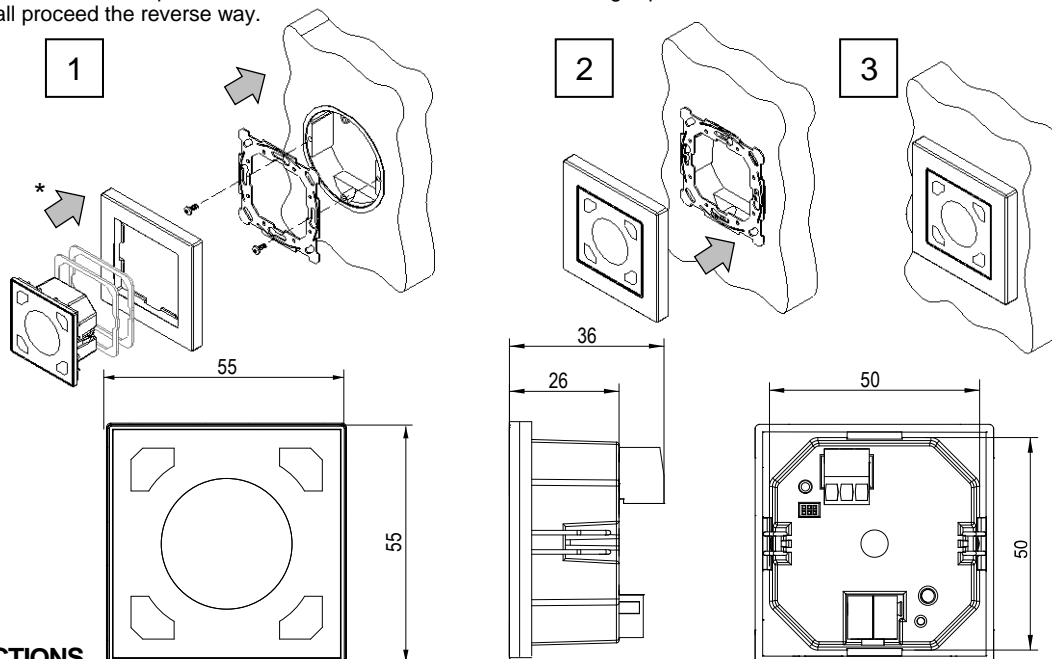

SAFETY INSTRUCTIONS

- Installation should only be performed by qualified professionals according to the laws and regulations applicable in each country.
- Do not connect the mains voltage nor any other external voltage to any point of the KNX bus; it would represent a risk for the entire KNX system. The facility must have enough insulation between the mains (or auxiliary) voltage and the KNX bus or the wires of other accessories, in case of being installed.
- Keep the device away from water and do not cover it with clothes, paper or any other material while in use.
- The WEEE logo means that this device contains electronic parts and it must be properly disposed of by following the instructions at <http://zennio.com/weee-regulation>.